

**Extra Strainer Basket for Internal Strainer  
(IS) Models W-150-IS, W-200-IS & W-250-IS  
Part# ST-20**

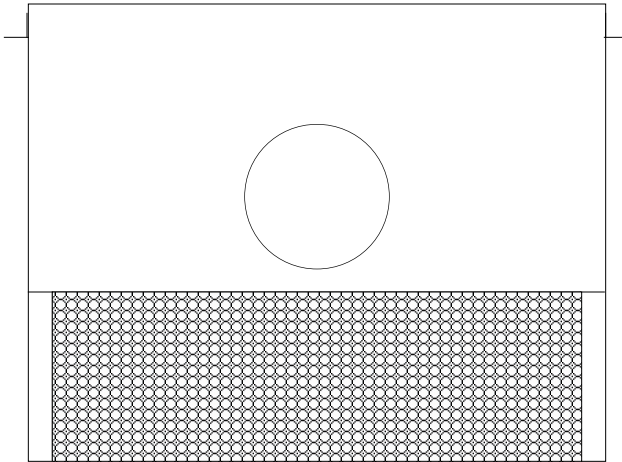

**Extra Strainer Basket for Internal Strainer  
(IS) Models W-350-IS & W-500-IS  
Part# ST-57**

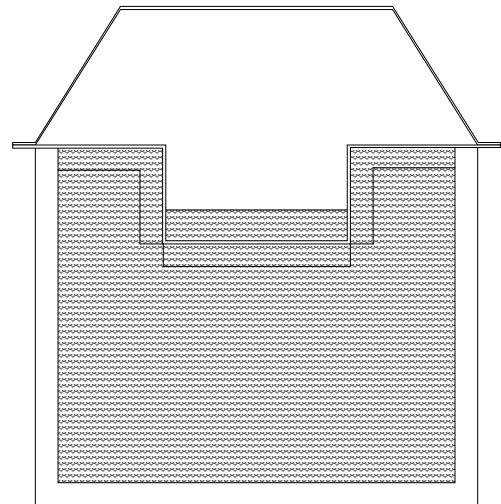

**Extra Strainer Basket for Internal Strainer  
(IS) Models W-750-IS & W-1250-IS  
Part# ST-97**

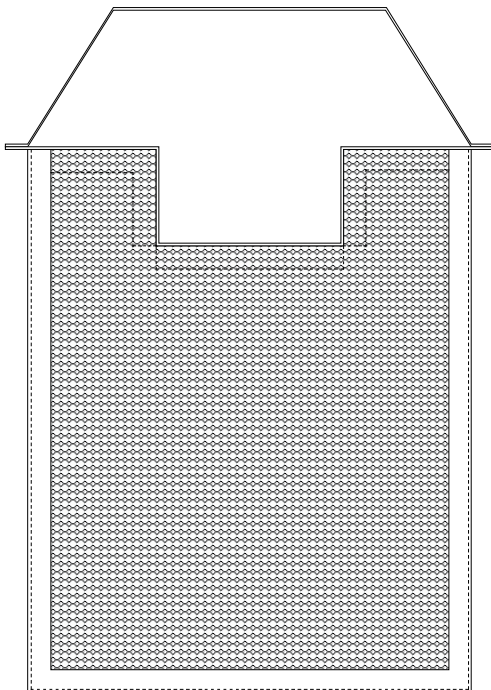

**Extra Grease Collector for all  
Big Dipper Models  
Part# GC-7**

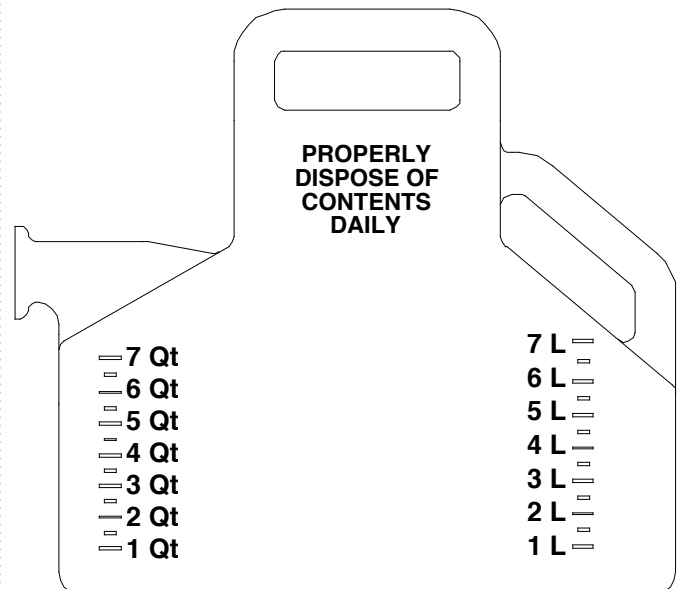

## SA-1 Sump Adapter

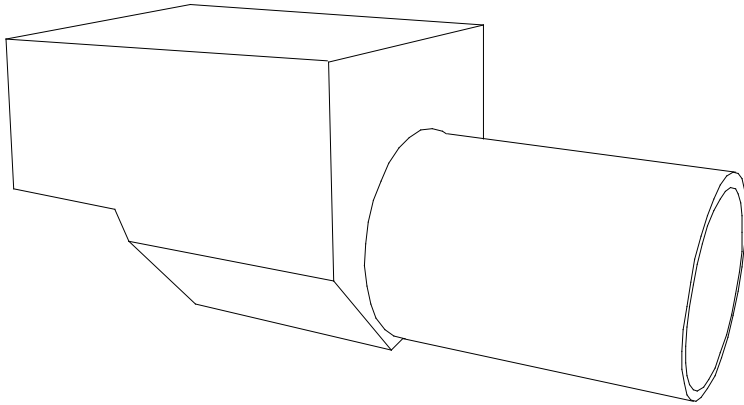

### SA-1 Sump Adapter

The Big Dipper® SA-1 Sump Adapter is a module that attaches to the grease sump outlet of Big Dipper Series Units. This module enables the customer to adapt the Big Dipper system (and using the SH-3 Sump Hose - order separately) to use a container other than the Grease Collector provided with the unit.

For example, use the SA-1 Sump Adapter with a Big Dipper Unit mounted on a support frame to empty grease into a 55-gallon drum.

#### Features:

- Stainless Steel Construction
- Easy Installation
- One Size Fits All Models

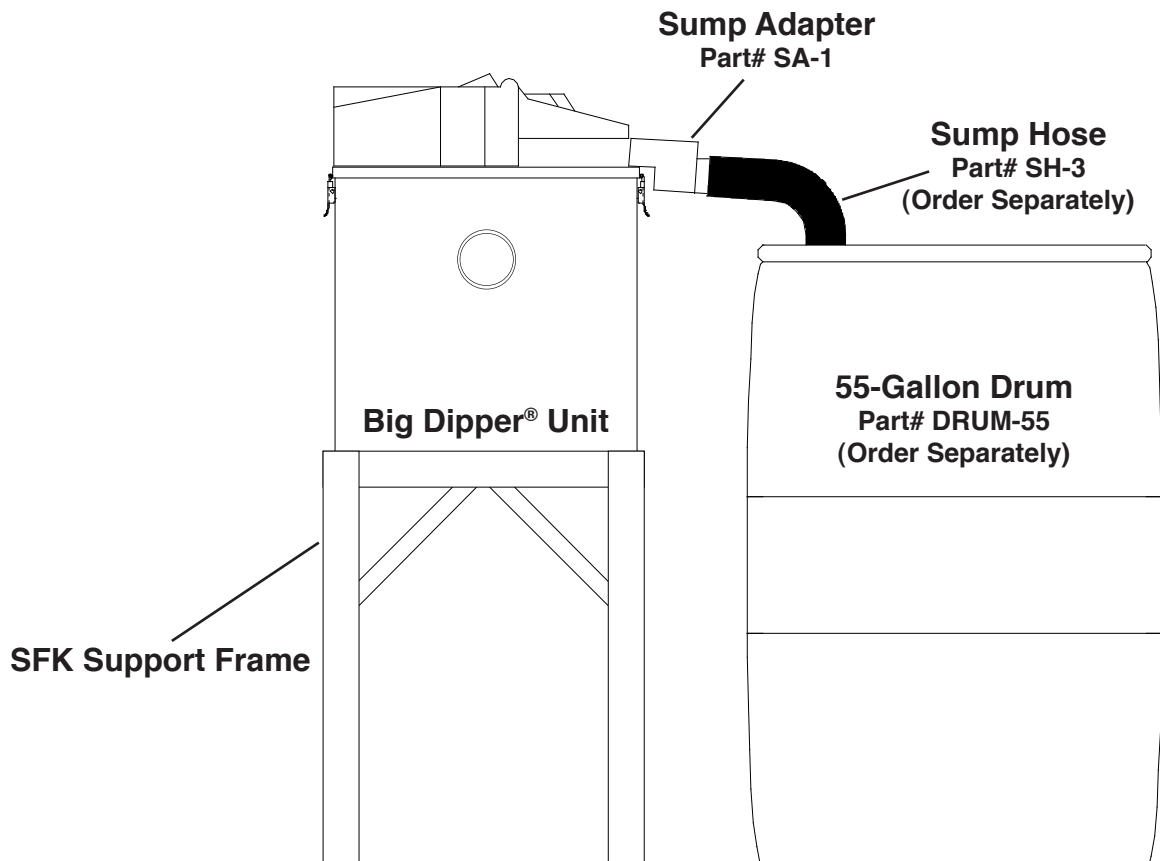

## FS-1 Flat Strainer For Point Source Use

The **Big Dipper® FS-1 Flat Strainer** is designed to eliminate the garbage disposal and reduce clogged drains due to coarse solids buildup. The Flat Strainer separates & collects coarse solids such as rice, cole slaw and other food scraps larger than 0.125" / 3.175 mm in diameter. The removable tray allows the customer to empty the collected coarse solids directly into a trash receptacle. The FS-1 is constructed of durable stainless steel and offers a simple solution for solids waste disposal.

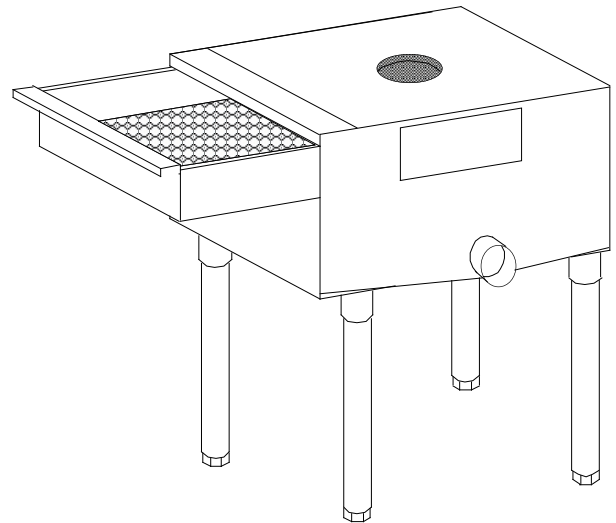

### FS-1 Flat Strainer Features

- **Stainless Steel Construction**
- **Field-Modifiable Polycarbonate Lid Cover**
- **Adjustable Height**
- **Removable Tray**

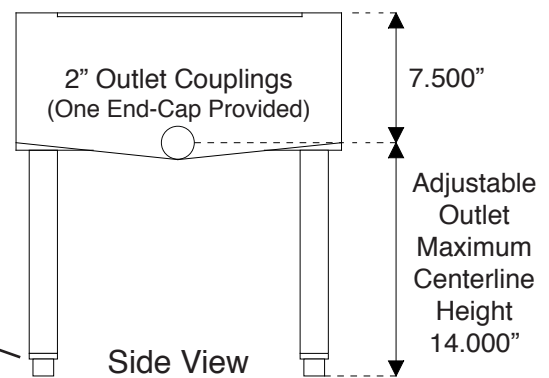
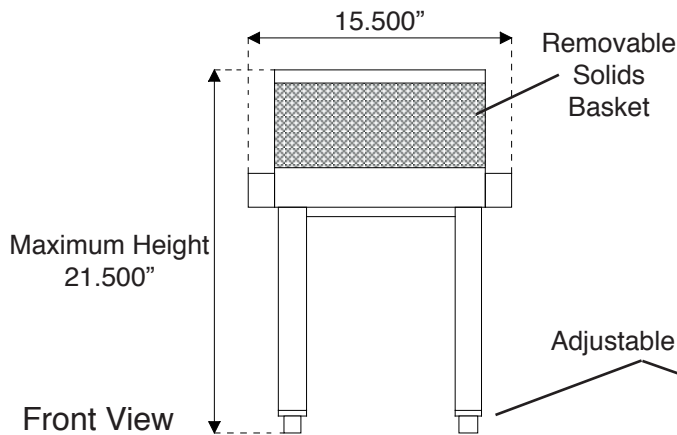
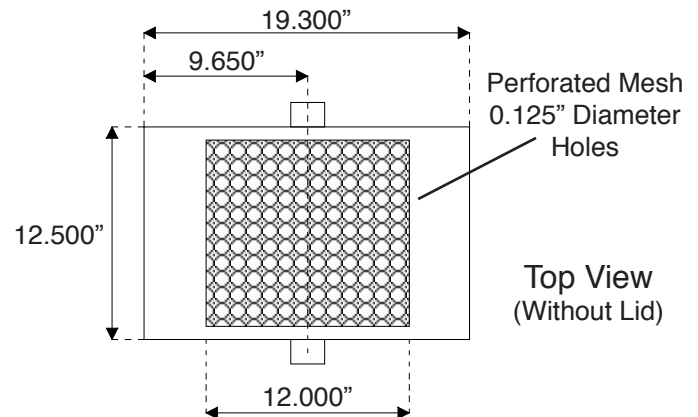
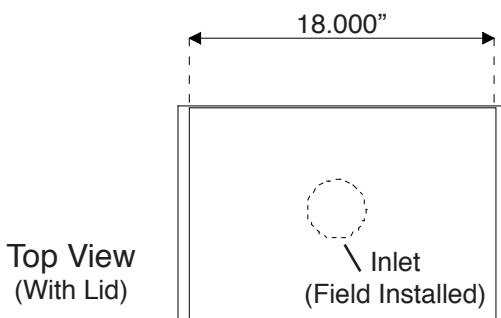

## FS-1 Flat Strainer

### FS-1 Servicing a Food Preparation Sink (Non-Grease Bearing Flows)

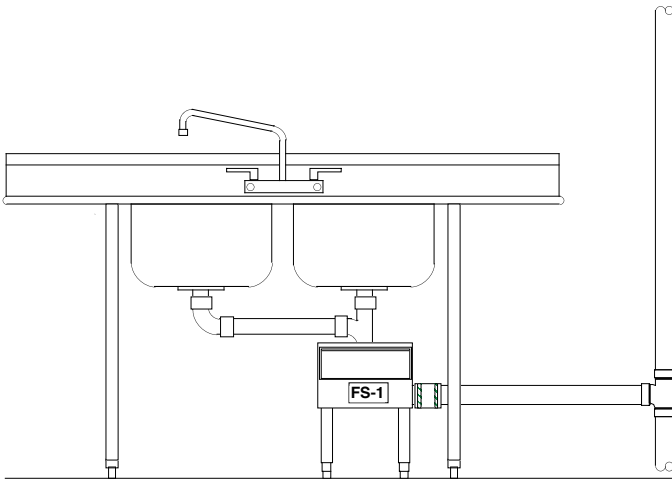

### FS-1 Servicing a Ware Washing Sink

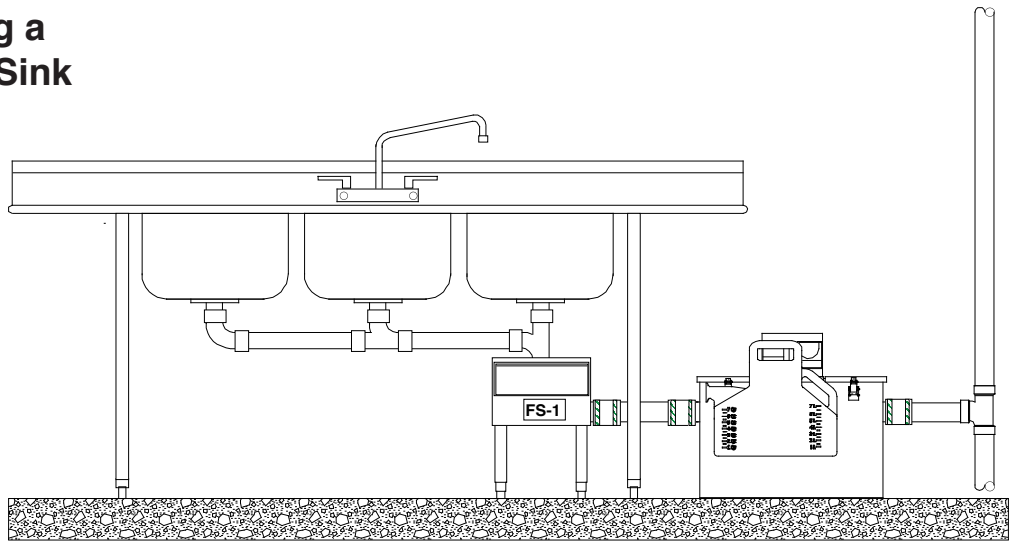

### FS-1 Servicing a Pre-Rinse Station

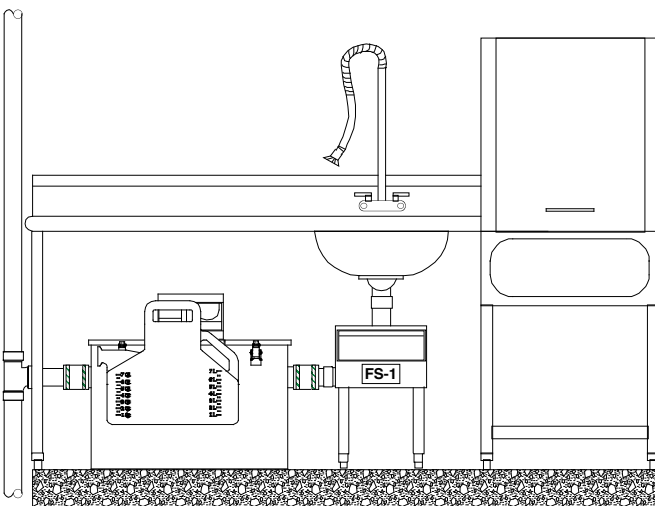

**NOTE:** Drawing for reference only. Equipment must be installed in compliance with all applicable laws, regulations and codes, including plumbing codes. Installation should be performed by a qualified plumber.

## ESU-1 External Strainer For Point Source Use

The Big Dipper® ESU-1 External Solids Strainer is designed for locations that require a separate external solids strainer to be installed in front of a grease interceptor. The ESU-1 separates & collects coarse solids such as rice, cole slaw and other similar foodstuffs (larger than 0.125" / 3.175 mm in diameter). The removable strainer basket allows the customer to empty the collected solids directly into a trash receptacle. The ESU-1 External Strainer is constructed of durable stainless steel and offers a simple solution for solid waste disposal. The ESU-1 couples with Big Dipper W-200-IS, W-250-IS & W-250-AST Point Source Automatic Grease & Oils Removal Units.

### ESU-1 External Strainer Features:

- **Stainless Steel Construction**
- **Removable Stainless Steel Strainer Basket**
- **1.16 Gallon Basket Capacity**

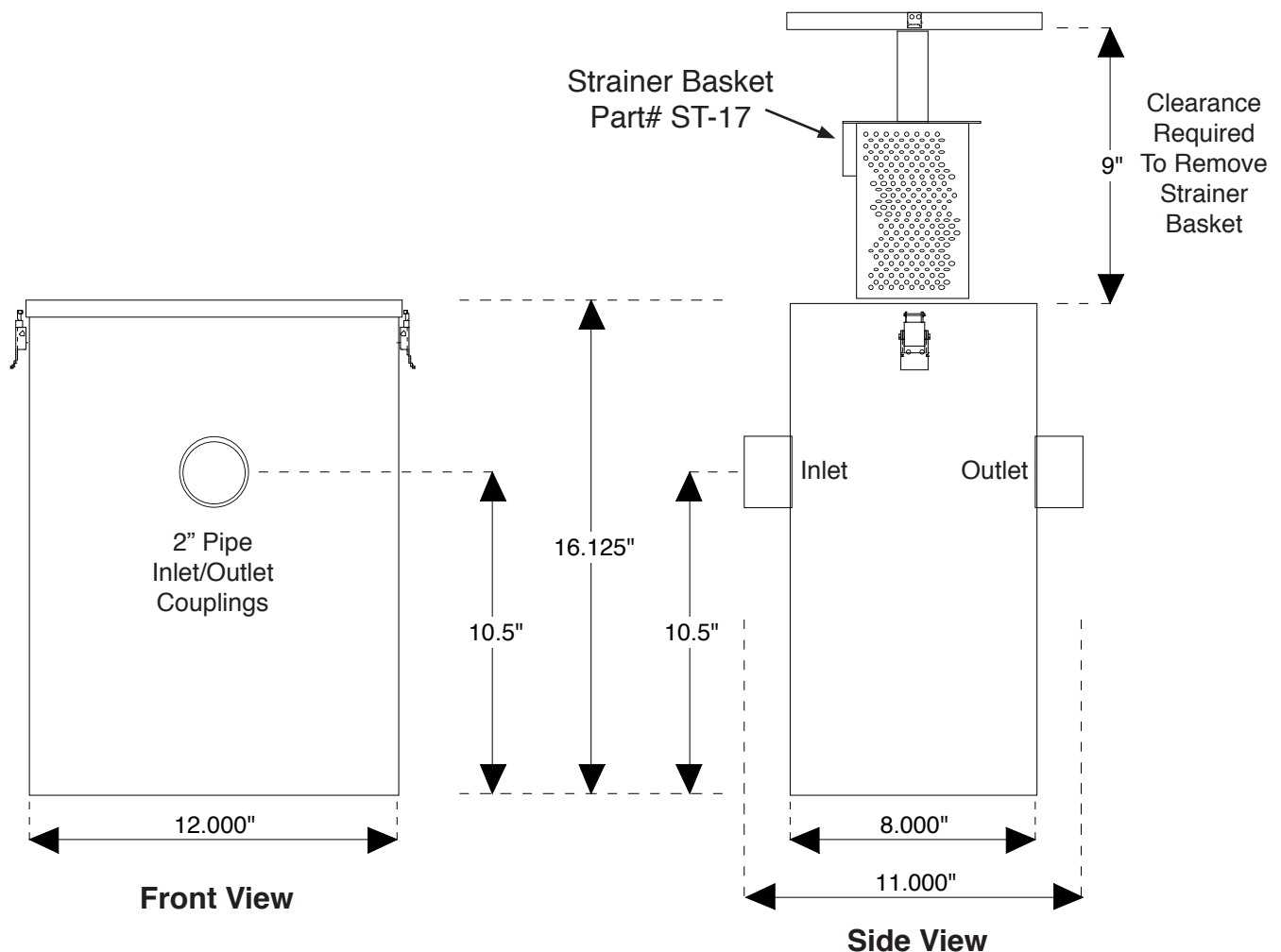

## ESU-1 External Strainer

### ESU-1 Servicing a Three Compartment Sink Coupled with a Big Dipper W-200-IS System

**NOTE:** Drawing for reference only. Equipment must be installed in compliance with all applicable laws, regulations and codes, including plumbing codes. Installation should be performed by a qualified plumber.

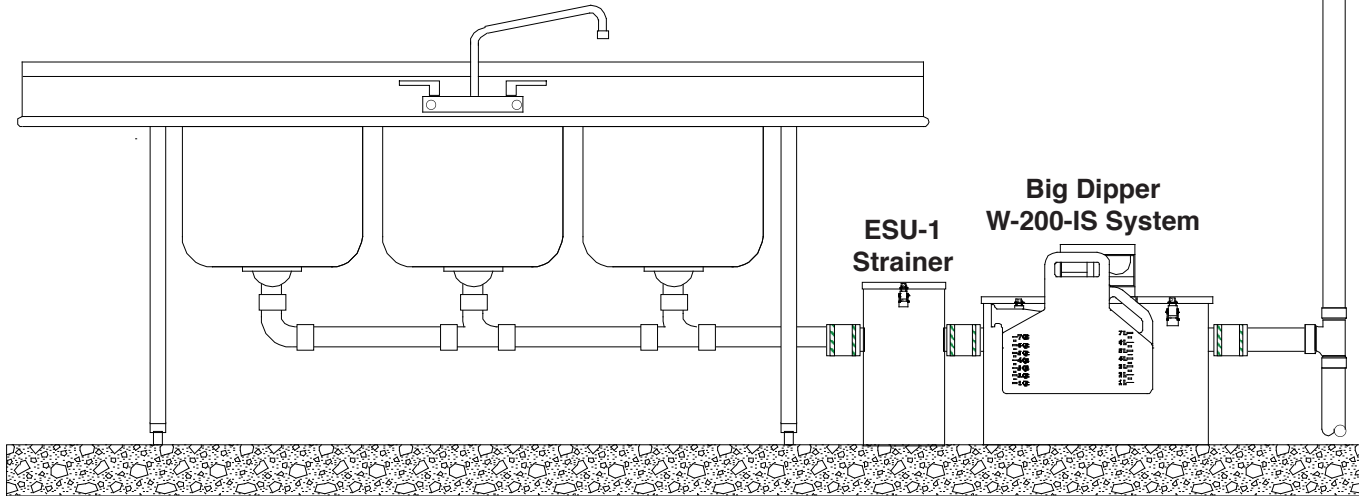

### ESU-1 Servicing a Pre-Rinse Sink Coupled with a Big Dipper W-200-IS System

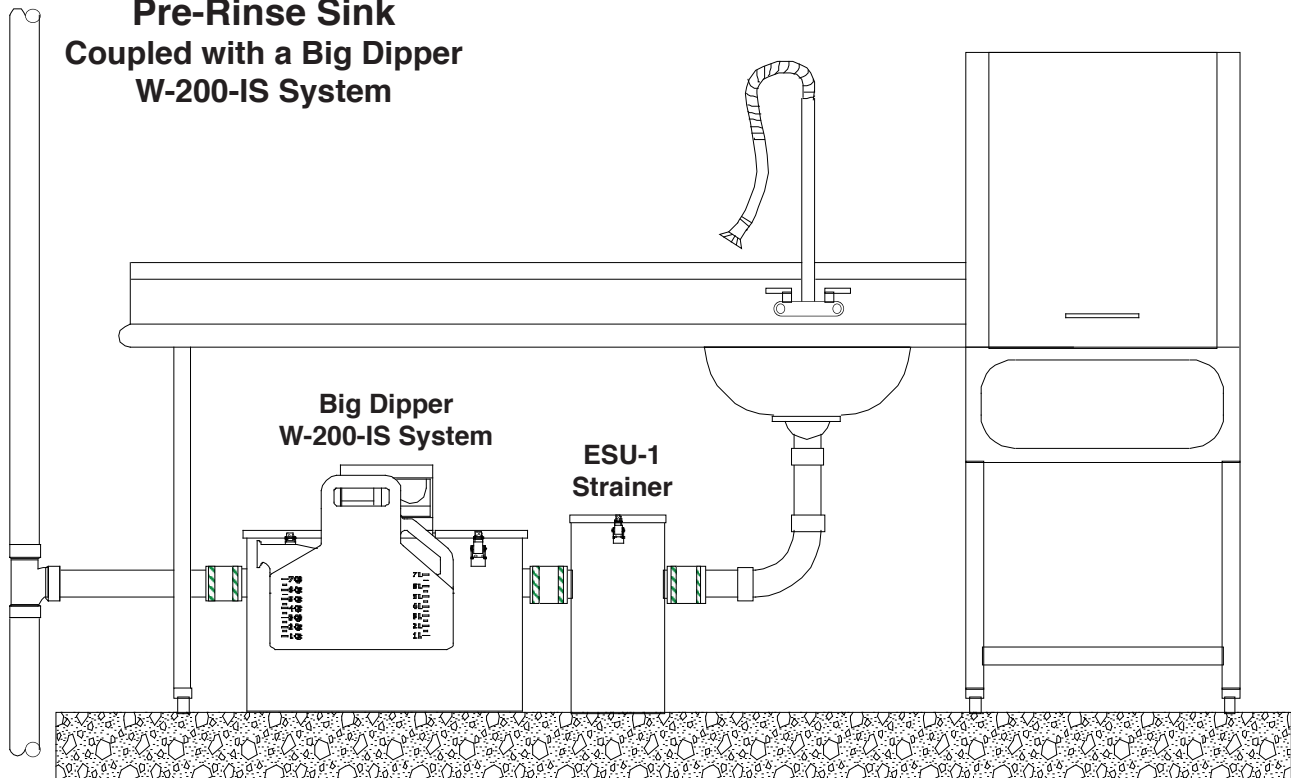

## ILS-1 In-Line Strainer For Institutional Kitchens

The ILS-1 In-Line Strainer separates and collects coarse solids larger than 1" (25 mm) in diameter found in typical institutional-type kitchen flows. This option is designed to couple with large Big Dipper Grease Removal Units (50 GPM and higher).

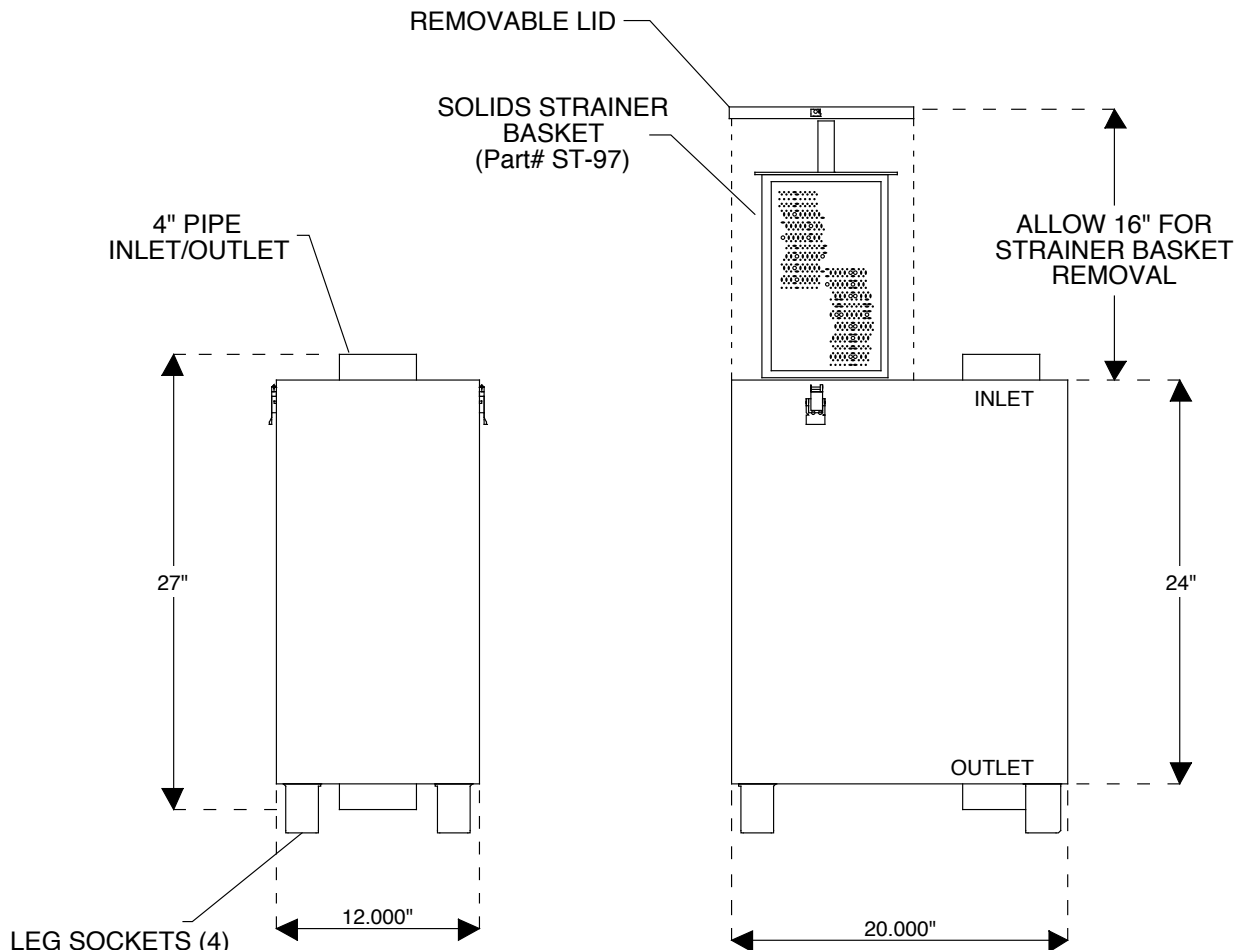

### Features:

- Stainless Steel Construction
- For Institutional-type installations where heavy loadings of coarse solids are present in kitchen drainwater
- Separates & collects coarse kitchen solids over 1" in diameter
- Solids less than 1" in diameter pass through into the Big Dipper® Unit
- Easy to clean strainer basket holds up to 4 gallons of solids
- Comes with four (4) 48" support legs for flexible installation

©2007 Thermaco, Inc. All rights reserved • Patented/Patents Pending • Specifications subject to change without notice

## ILS-1 In-Line Strainer

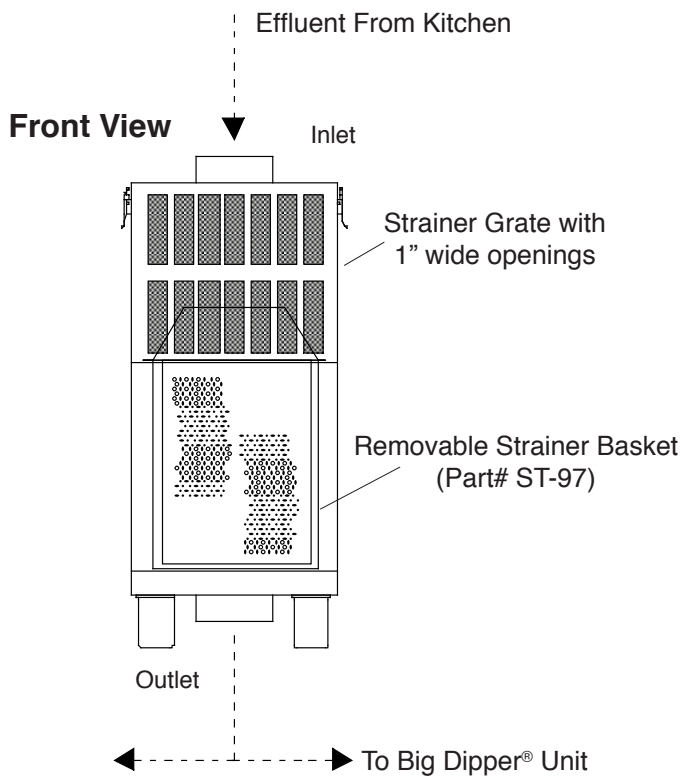

### How does the ILS-1 In-line Strainer Work?

As kitchen effluent flows into the ILS-1 In-line strainer from the top, it passes over a grate. This grate has openings that are 1" wide. This strains out any coarse solids that are greater than 1" in diameter. These solids slide down the grate and into a Strainer Basket. This basket is removable, and should be emptied a minimum of once per day, more often if the kitchen is busy. These strained solids may be emptied into a trash receptacle.

Meanwhile, the strained effluent exits the unit through a coupling on the bottom. This flow continues on to a Big Dipper® Automatic Grease & Oils Removal Unit. This unit captures and removes incidental solids less than 1" in diameter as well as trapping and removing any free-floating fats, oils and grease.

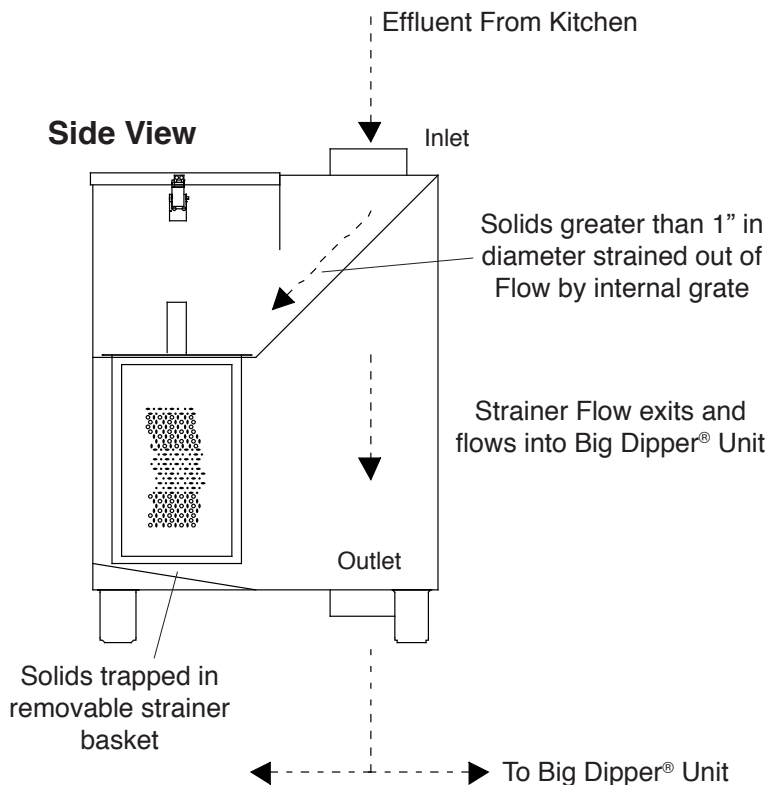

**ILS-1 In-Line Strainer**

The Big Dipper® ILS-1 In-Line Strainer and Big Dipper® Grease Removal Unit in a basement installation.

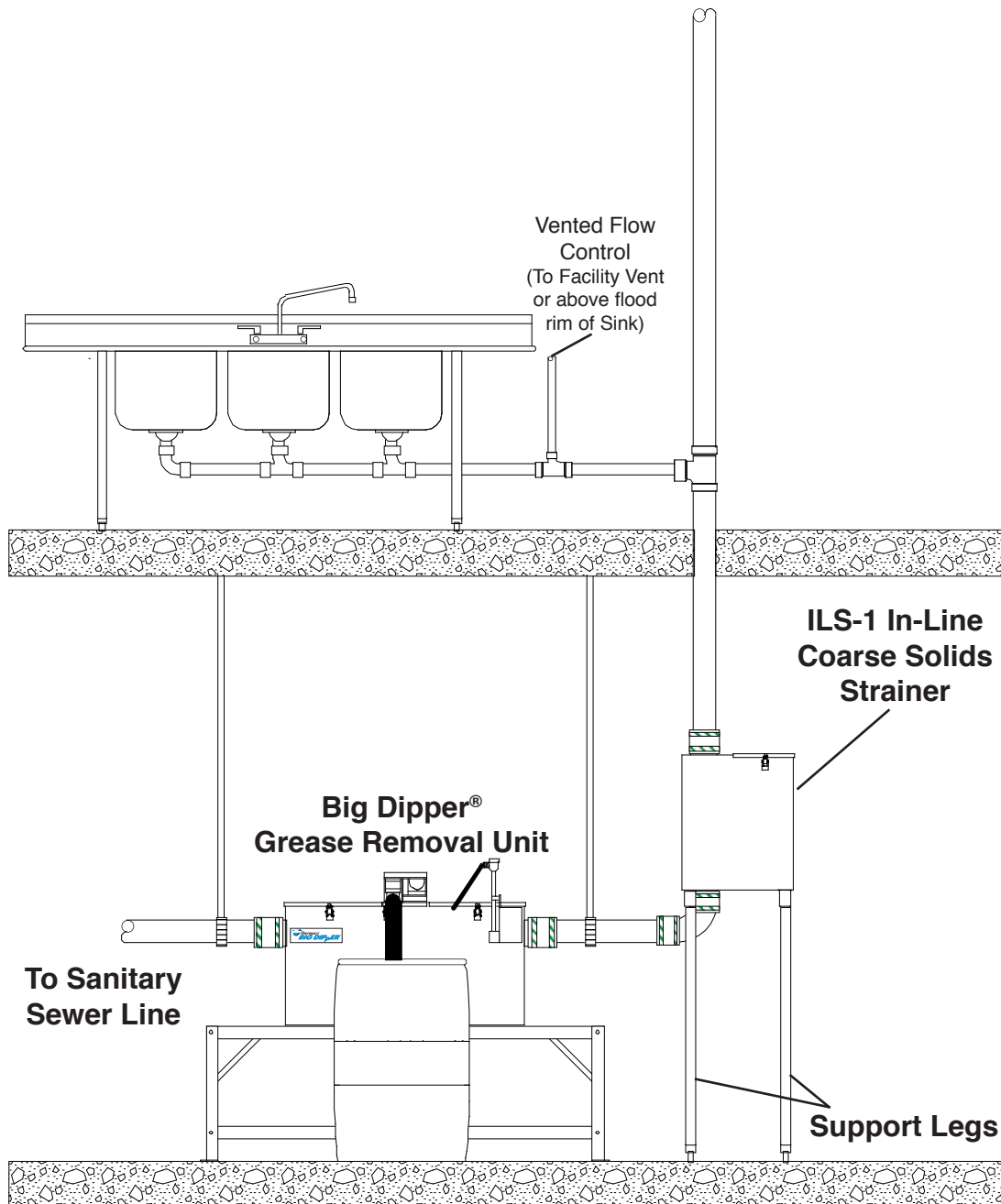

**NOTE: Drawing for reference only. Equipment must be installed in compliance with all applicable laws, regulations and codes, including plumbing codes. Installation should be performed by a qualified plumber.**

## HAG Air Gap Assembly



Big Dipper® HAG-2 Servicing a W-150-IS Unit

The Big Dipper® HAG Horizontal Air Gap Assembly Kit offers a simple yet effective method for providing an air gap for meeting health department or plumbing code requirements. Among the many different methods of creating an air gap to protect against cross-contamination, the most popular is an air gap directly between the sink discharge and the outflow piping. This means that in the event of a backup, effluent will spill out of this gap under the sink discharge and directly onto the floor without any danger of cross-contamination. The optional field-installable HAG-BA-1 Solids Strainer Baskets collect incidental solids from the drain flow.

## How Does the HAG Air Gap Assembly Work?

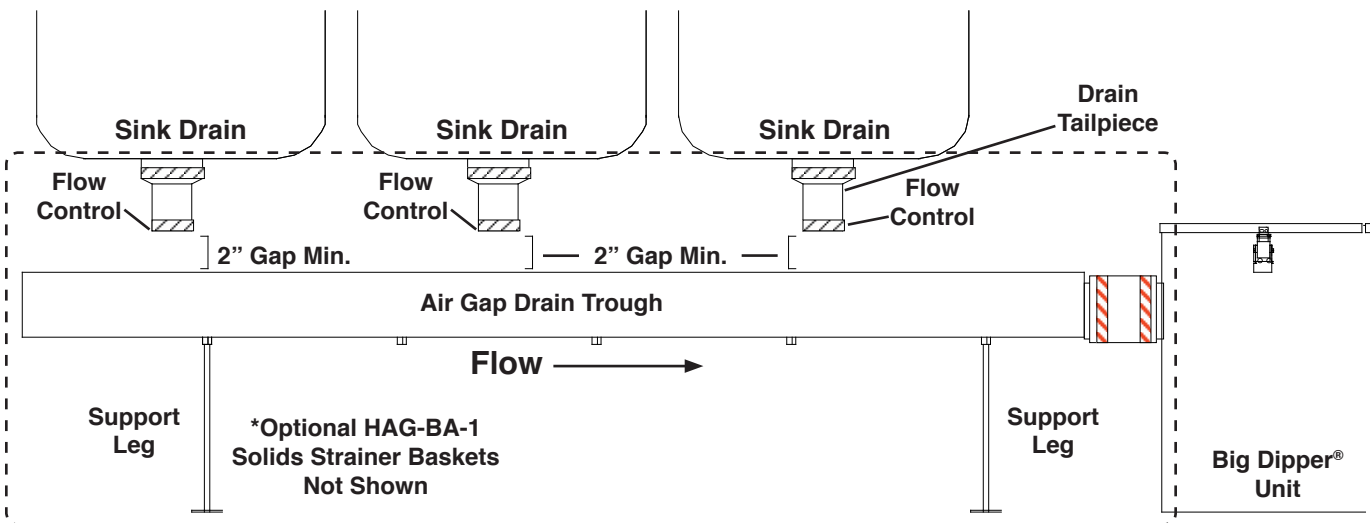

As the sink drains, effluent flows into the all stainless steel construction HAG Air Gap. The flow is slowed down by flow controls (provided) attached at the end of each drain stem. There is a 2" (or greater) gap between the bottom of the drain tailpiece and the drainage piping. In the event of a blockage downstream of the sink, effluent flows out of this 2" gap onto the kitchen floor preventing any cross-contamination between the sinks or contamination from effluent. The HAG Air Gap may also be plumbed through a Big Dipper® Automatic Grease & Oils Removal Unit. Incidental solids in the flow may be strained and collected using the optional, field-installable HAG-BA-1 Solids Strainer Baskets. The HAG is mounted to the floor using threaded rod support legs and feet (supplied). A Bracket that mounts the HAG assembly to the wall is also provided.

### HAG-2 Horizontal Air Gap Trough Component

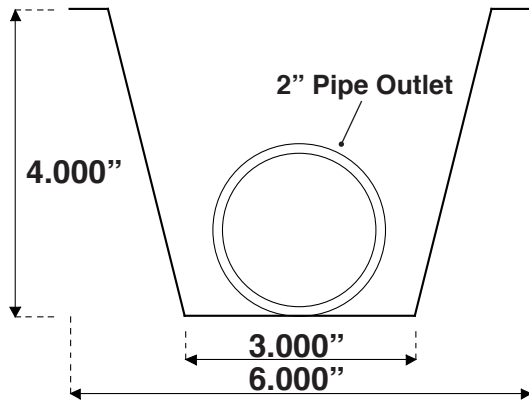

**Outlet View**

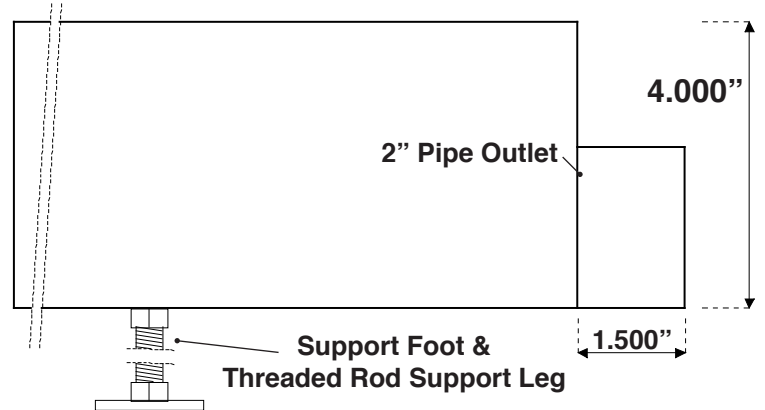

**Side View**

\* The HAG-2 Air Gap is shipped in 72" lengths. It is field-trimmed to fit the application. It is recommended 8" be left behind the drain valve that is furthest from the Big Dipper® unit. The threaded rod supports & wall mount brackets must also be trimmed to fit the sink installation. A 1/4" drop should be used for every 1' of run.

### HAG-3 Horizontal Air Gap Trough Component

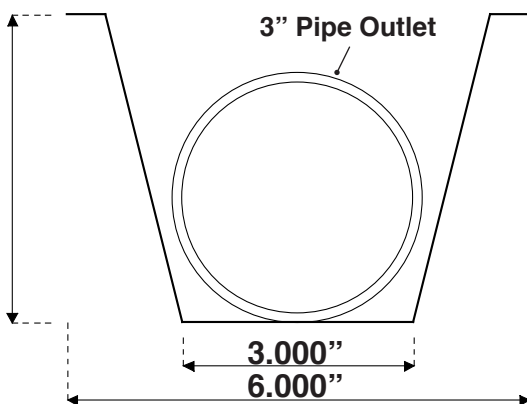

**Outlet View**

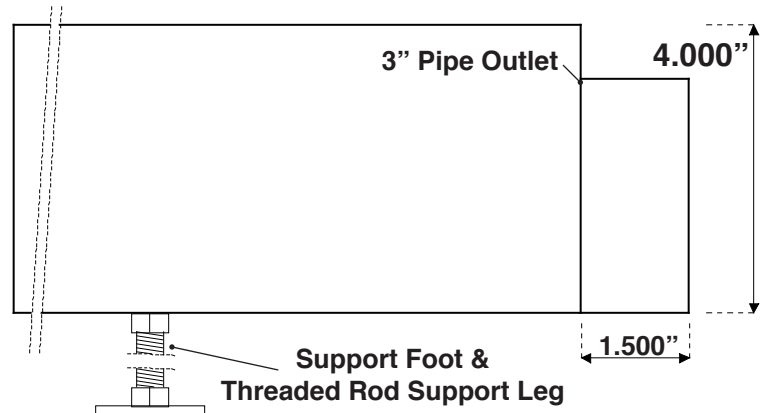

**Side View**

\* The HAG-2 Air Gap is shipped in 72" lengths. It is field-trimmed to fit the application. It is recommended 8" be left behind the drain valve that is furthest from the Big Dipper® unit. The threaded rod supports & wall mount bracket must also be trimmed to fit the sink installation. A 1/4" drop should be used for every 1' of run.

## HAG Air Gap Layouts

### Model HAG-2

- 2" Outlet
- Optional HAG-BA-1 Strainer Baskets Shown Installed

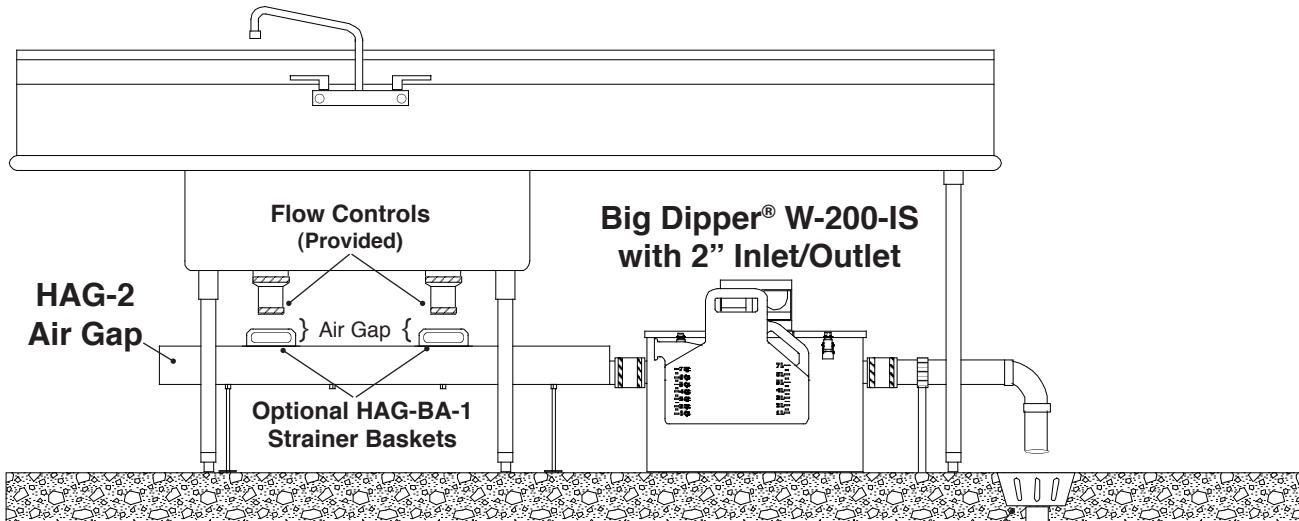

### Specify HAG-2 for 2" Sink Drain Piping

- Support Legs & Wall Mount Bracket Supplied
- Minimum slope of 1/4" drop per 12" run necessary for proper operation
- All Stainless Steel Construction

Floor Sink  
To Sanitary Sewer Line

### Model HAG-3

- 3" Outlet
- Optional HAG-BA-1 Strainer Baskets Shown Installed

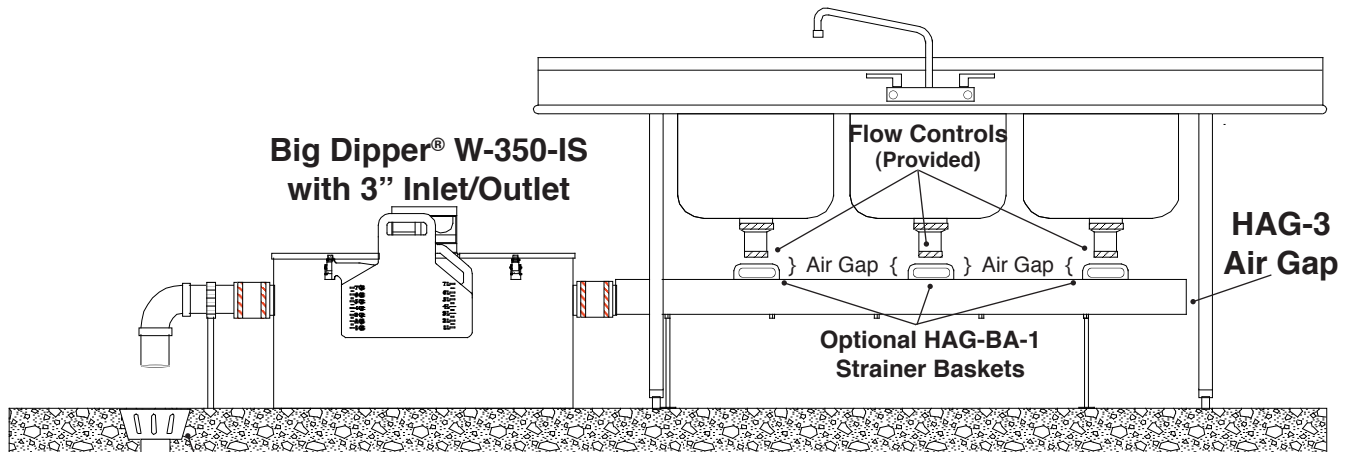

### Specify HAG-3 for 3" Sink Drain Piping

- Support Legs & Wall Mount Bracket Supplied
- Minimum slope of 1/4" drop per 12" run necessary for proper operation
- All Stainless Steel Construction

Floor Sink  
To Sanitary Sewer Line

**NOTE: Drawing for reference only. Equipment must be installed in compliance with all applicable laws, regulations and codes, including plumbing codes. Installation should be performed by a qualified plumber.**

## **HAG-BA-1 Solids Strainer Baskets (Optional)**

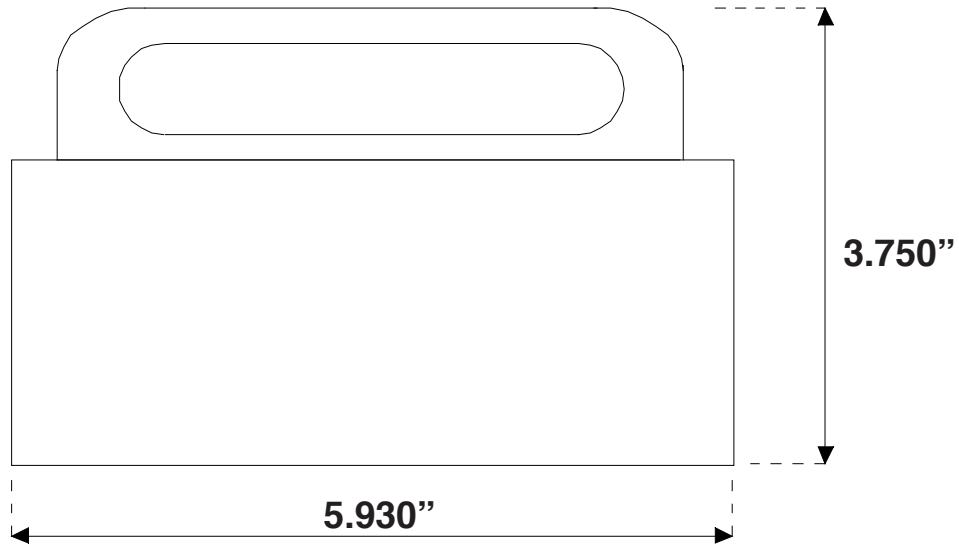

**End View**

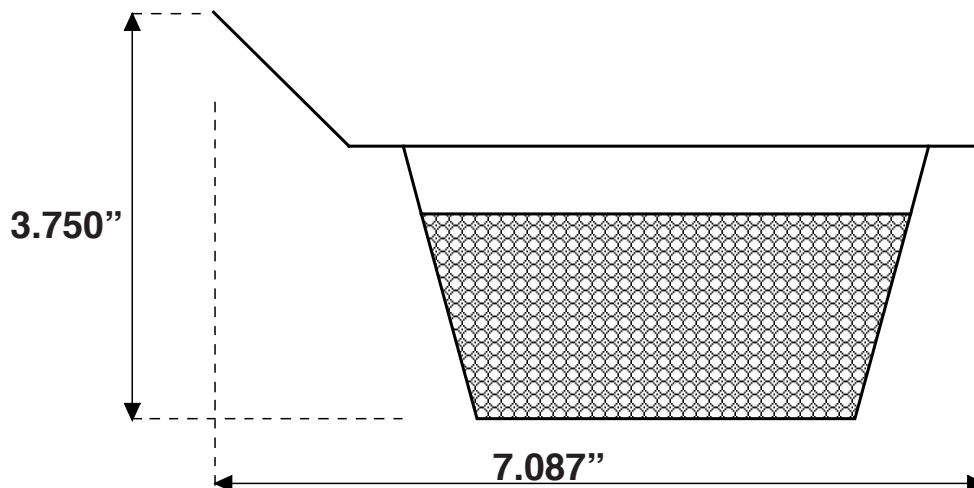

**Side View**

The Optional **HAG-BA-1 Solids Strainer Baskets** separate and collect incidental food solids that are contained within the drain flow. These collected, dewatered solids may be then disposed of in the trash receptacle. One HAG-BA-1 Solids Strainer Basket is required per sink drain/sink bowl. For example, a typical three compartment sink will require three HAG-BA-1 Solids Strainer Baskets. Each HAG-BA-1 is ordered individually.

## AP-6000-1 Alarm Probe

The Big Dipper® AP-6000-1 Series Alarm Probe is designed to provide an early warning that maintenance is required on Big Dipper systems. It may be easily installed in the option port located behind the Big Dipper skimming wheel enclosure (specify the model AP-6000-1-TK for this application). The AP-6000-1-TK alarm probe activates a warning tone to signal excessive grease accumulation inside the unit. The system may then be checked and corrected **before** the grease & oil level exceeds the maximum retention capacity of the unit. The alarm probe may also be installed in a grease collection barrel (specify model AP-6000-1-DR for this application) to signal when the collection barrel needs to be emptied. This option is especially important when the Big Dipper unit is installed in basements or other “out-of-sight” locations. An optional Alarm Probe with a dry contact connection for a visual flashing light is also available (please specify AP-6000-1-TKDC for Big Dipper installation and AP-6000-1-DRDC for grease collector installation).

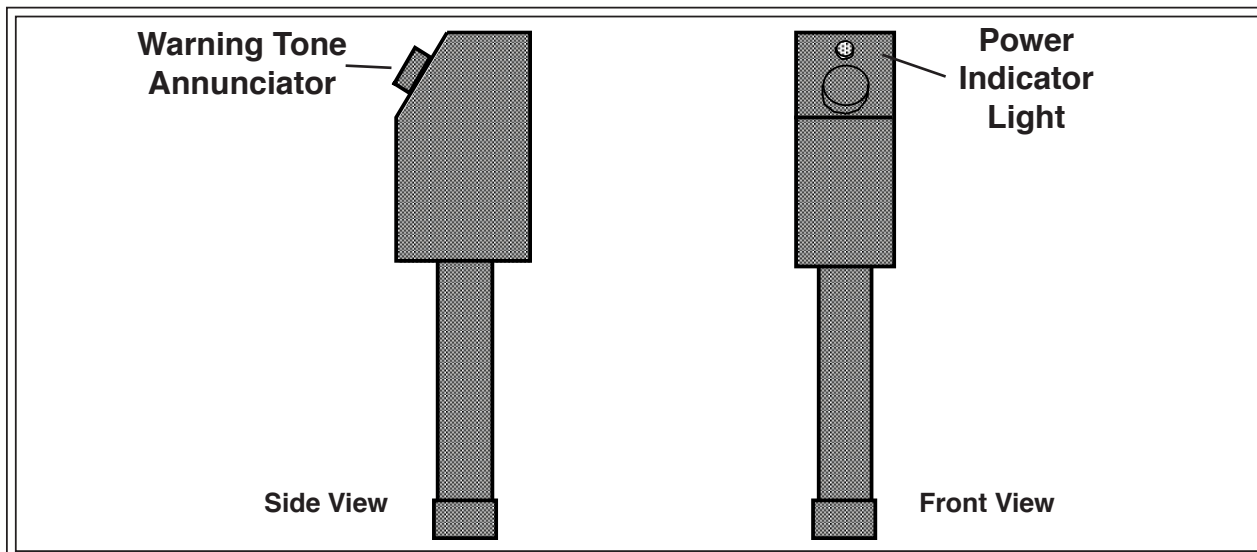

### Electrical Specifications\*:

#### AP-6000-1-DR & AP-6000-1-TK

115 VAC, 60 Hz, 4.5 Watts

#### AP-6000-1-DRDC & AP-6000-1-TKDC

115 VAC, 60 Hz, 4.5 Watts, 10 Amp, 250 VAC switching capability

\* 230V, 50 Hz Alarm Probes Available

### Features:

- Field-installable
- Durable probe with electronics encased in molded polyethylene
- Solid state; no moving parts
- Comes fully calibrated & ready to use

### Please Note:

- Specify AP-6000-1-TK if mounted to the Big Dipper Unit
- Specify AP-6000-1-DR if mounted to a grease collection barrel
- Specify AP-6000-1-TKDC\* for optional dry contact for warning light with Big Dipper Unit
- Specify AP-6000-1-DRDC\* for optional dry contact for warning light with grease collection barrel

\*Warning Light not supplied with Alarm Probe

### AP-6000-1-TK Alarm Probe For Big Dipper® Unit

This schematic displays a Big Dipper® and an AP-6000-1-TK Alarm Probe as configured for a Big Dipper unit. This configuration allows monitoring of collected grease & oils within the Big Dipper unit itself. When the grease level builds up in the Big Dipper where it makes contact with the AP-6000-1-TK probe, the warning tone activates. The system may then be checked and corrected **before** the grease & oil level exceeds the maximum retention capacity of the unit.

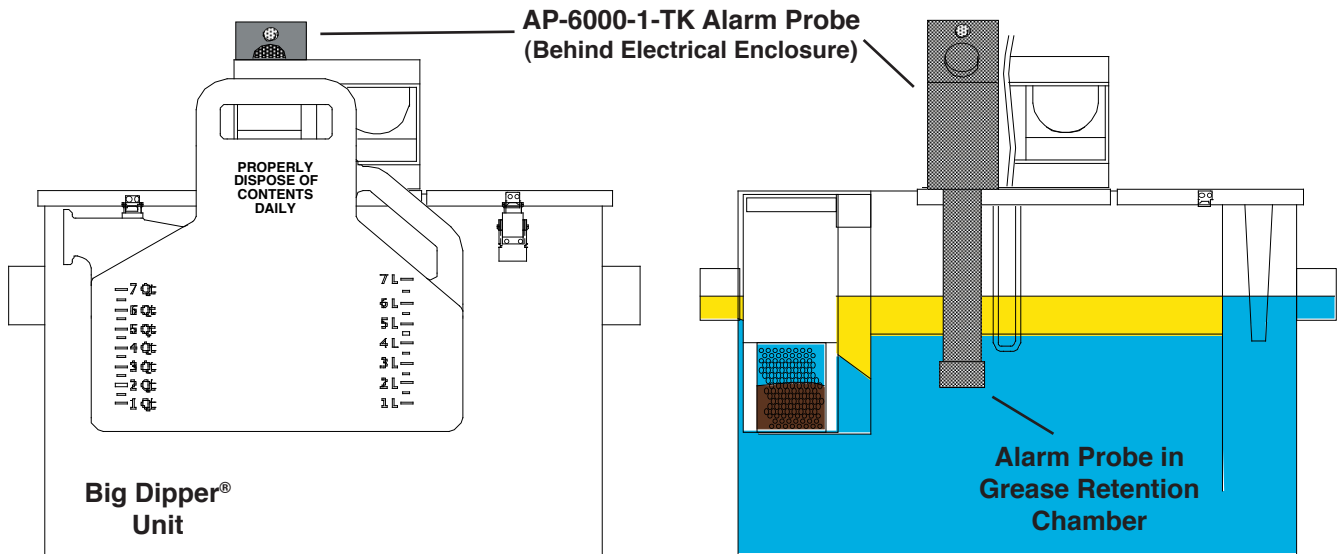

Side View

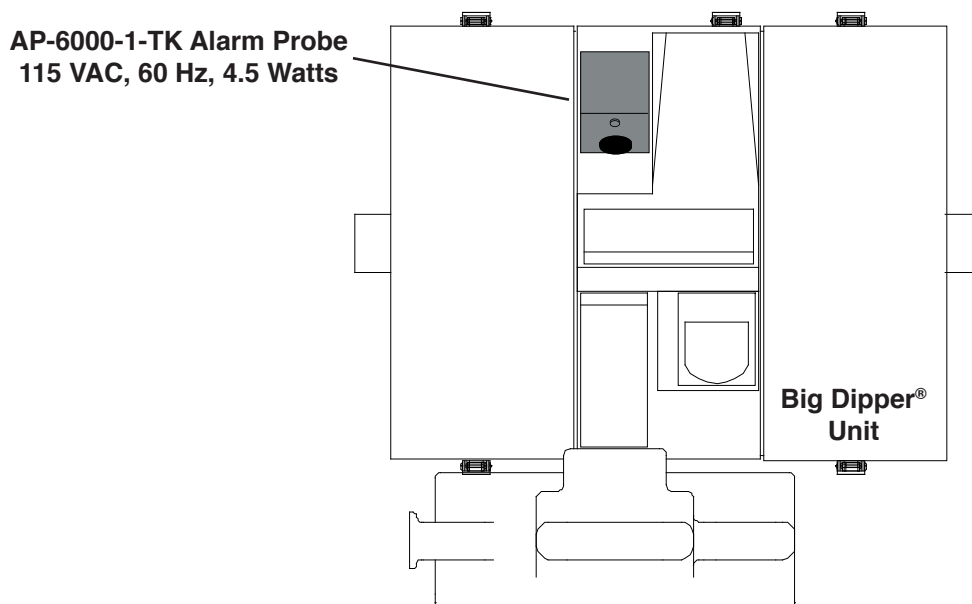

Top View

## AP-6000-1-DR Alarm Probe For Collection Container

### AP-6000-1-DR Alarm Probe For Grease Collection Container

This schematic displays a Big Dipper® unit and an AP-6000-1-DR Alarm Probe as configured for a grease collection barrel. This configuration allows monitoring of collected grease & oils within the grease collector. When the grease level rises high enough to make contact with the AP-6000-1-DR probe, the warning tone activates.

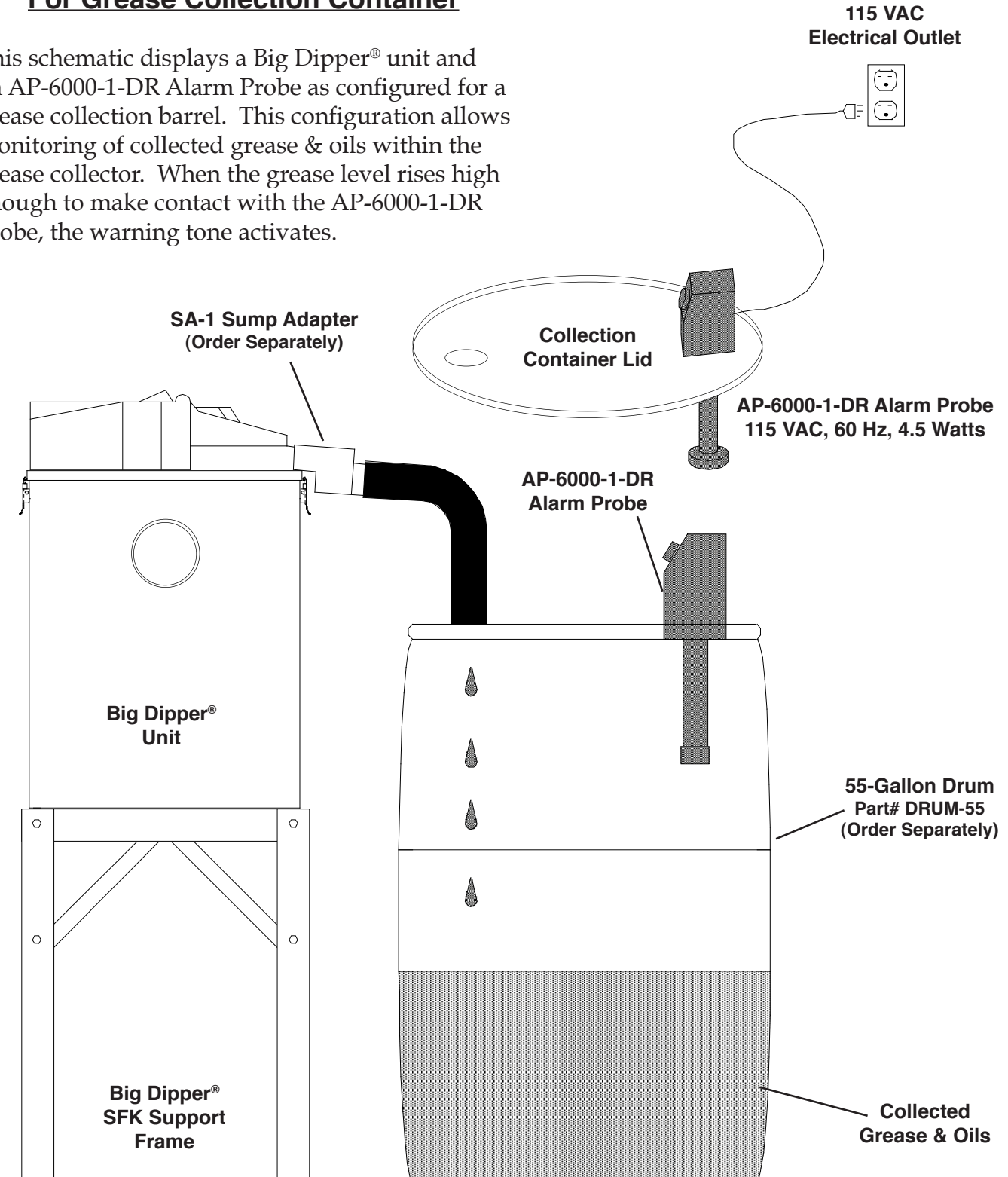

## SFK Support Frame Kits Model W-150-IS through W-250-IS

### Big Dipper Unit Support Frame Kits

For those applications requiring Big Dipper units to be raised off the floor to accommodate sanitation, the optional SFK-150 Support Frame Kit is available. This Frame raises W-150-IS through W-250-IS Units off of the floor directly at the source. The sturdy, compact design lends itself easily to tight installations.

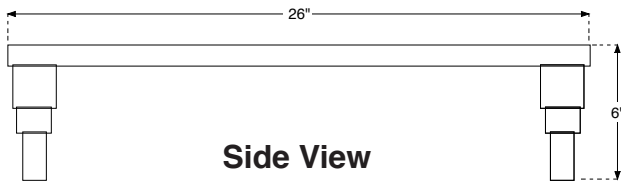

Side View

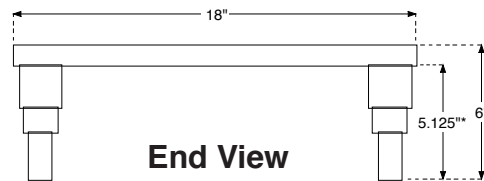

End View

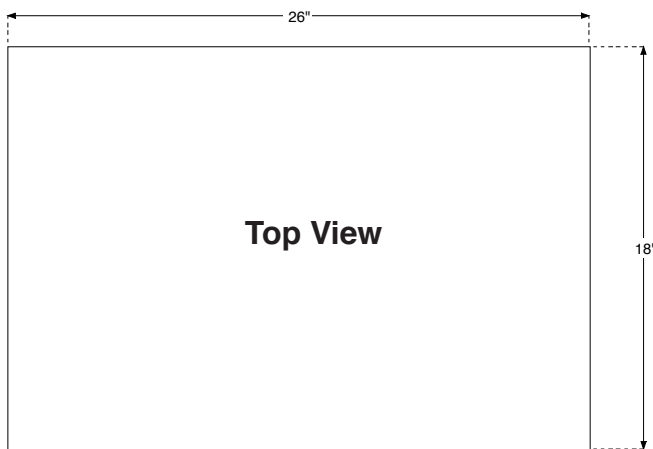

Top View

\* Maximum Effective Height - unit will rest on this level. The SFK-150 has Adjustable Legs.

#### SFK-150

- For Models W-150-IS , W-200-IS, W-250-IS & W-250-AST
- Stainless Steel Construction
- Adjustable Legs



Big Dipper® W-150-IS & SFK-150 Support Frame

## SFK Support Frame Kits W-200-IS Through W-350-IS

### Big Dipper Unit Support Frame Kits

For those applications in a basement or another location requiring Big Dipper units to be raised off the floor, the optional SFK Support Frame Kit is available. The sturdy, compact design lends itself easily to tight installations. The height of the frames allows use of the DRUM-55 Grease Collector when coupled with the SA-1 Sump Adapter Kit. Shipped ready to assemble.

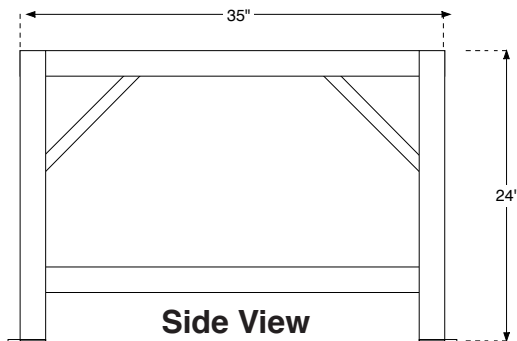

Side View

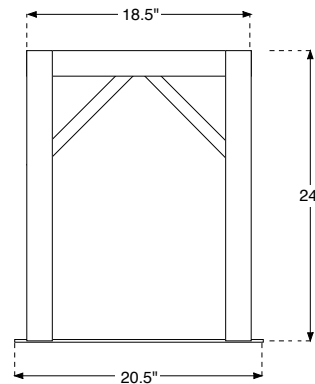

End View

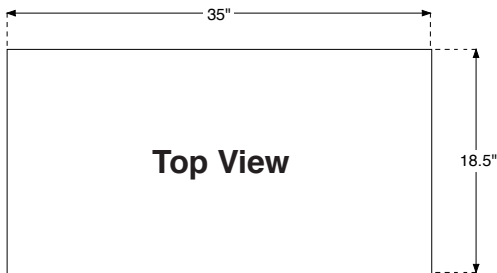

Top View

#### **SFK-200-350**

- For Models W-200-IS , W-250-IS, W-250-AST & W-350-IS
- Stainless Steel Construction
- Use with 55 Gallon Grease Barrel (DRUM-55)



**Big Dipper® W-1250-IS & SFK-1250 Support Frame**

## SFK Support Frame Kits W-500-IS Through W-1250-AST

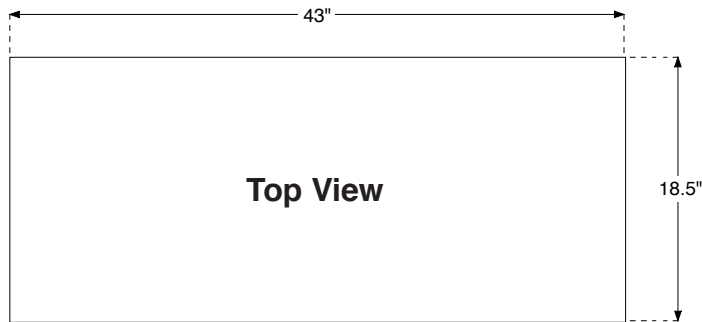
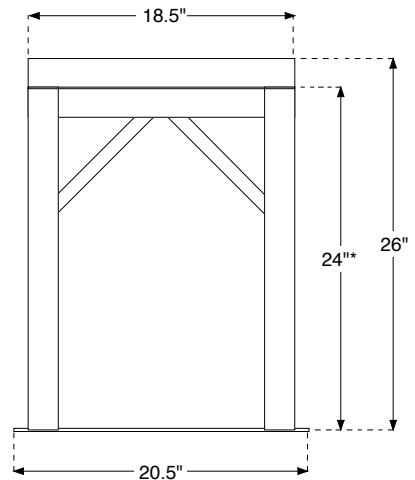
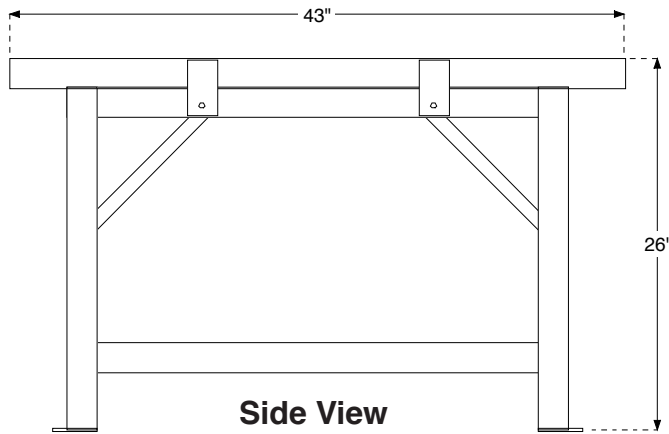

\* Effective Height - unit will rest on this level

### **SFK-500-750**

- For Models W-500-IS , W-750-IS & W-750-AST
- Stainless Steel Construction
- Use with 55 Gallon Grease Barrel (DRUM-55)

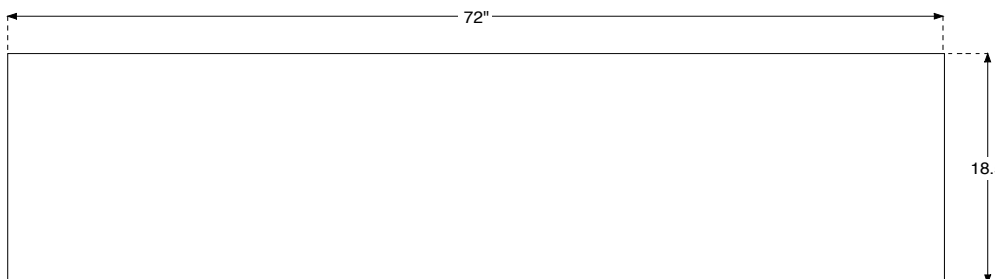
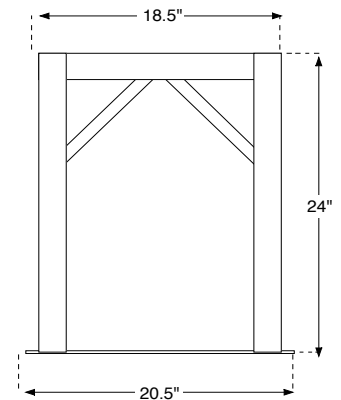
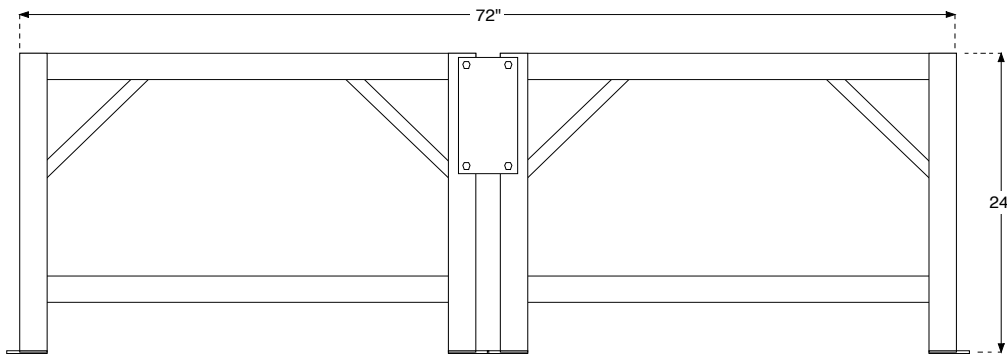

### **SFK-1250**

- For Models W-1250-IS & W-1250-AST
- Stainless Steel Construction
- Use with 55 Gallon Grease Barrel (DRUM-55)

Rotisserie Ovens, Combi-Steam Ovens and similar cooking devices are becoming more popular in commercial kitchen applications. The effluent that drains from these ovens is richly laden with fats. The piping from these ovens quickly clogs with grease. A Big Dipper® unit can solve this problem.

Another issue faced with this type of installation is that there is no ready water supply to keep the static water level of the grease interceptor at a normal level. As the skimming wheel removes the grease, there is no sink draining into the unit to replenish the displaced grease & oils.

To address both of these issues, Thermaco, Inc. has designed the **SWS-1 Supplemental Water Supply System** to be used in conjunction with a Big Dipper W-150-IS, W-200-IS and W-250-IS Point Source Grease Removal Units. The SWS-1 allows the Big Dipper® unit to be installed directly to the Oven, while the water replenishment system supplies a flow of water to replace the removed grease. This allows the static water level inside the Big Dipper to remain at a normal level.

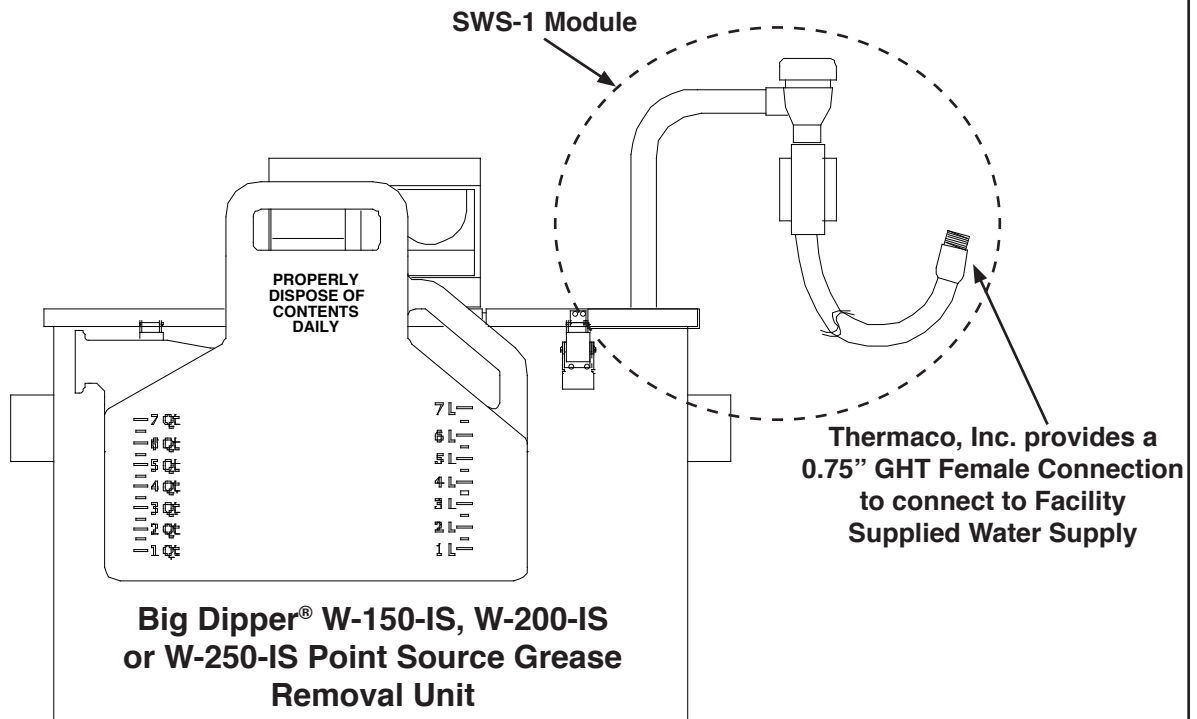

**Electrical Requirements\*:**

120V, 60 Hz, 20 W, 0.5 Amps

**Water Requirements (Supplied by Facility):**

5 Gallons per Hour, 40 - 70 PSI

\* A 230V, 50 Hz SWS-1 is also available.

**SWS-1 Side View**  
Coupled with Big Dipper  
W-200-IS Unit

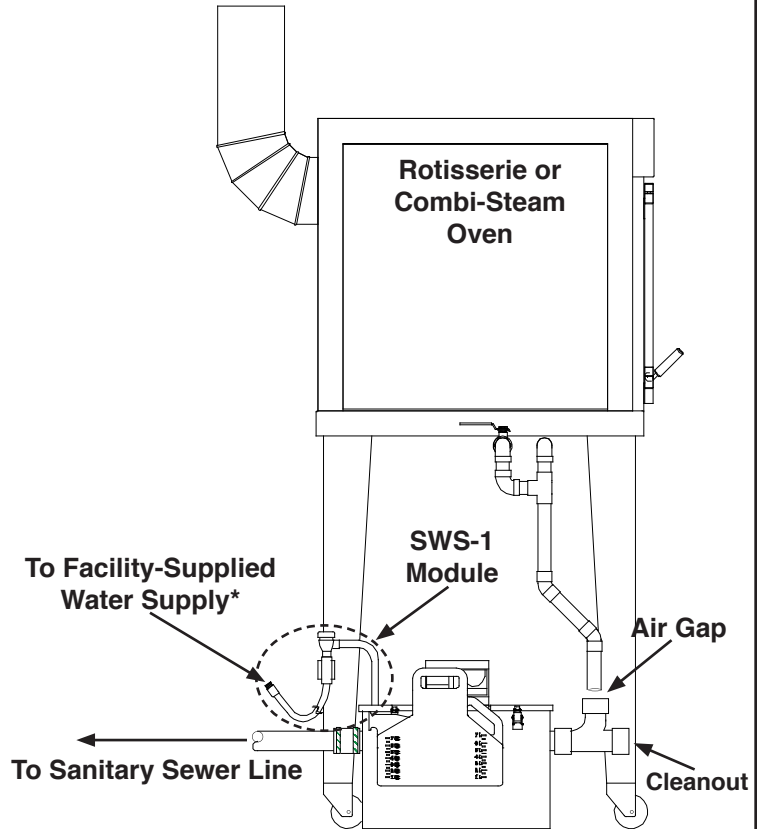

\* Thermaco, Inc. provides a 0.75" GHT Female Connection to connect to Facility-Supplied Water Supply

**SWS-1 Front View**  
Coupled with Big Dipper  
W-200-IS Unit

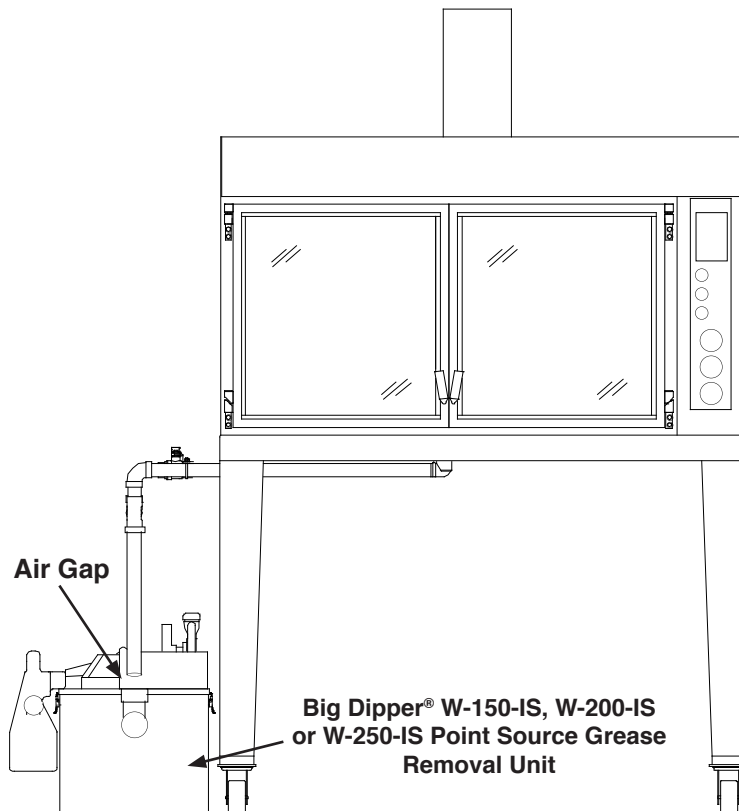

Ovens on Wheels may be moved for optimum position over the Air Gap

**NOTE:** Drawing for reference only. Equipment must be installed in compliance with all applicable laws, regulations and codes, including plumbing codes. Installation should be performed by a qualified plumber.

The Big Dipper® FSH Horizontal Flow Splitter Module splits a single effluent flow exiting a kitchen into two separate, equal flows in large institutional-type installations or for sites that need central grease removal but have a small footprint. The kitchen flows are diverted into twin Big Dipper Units installed horizontally beside one another. For example, couple two W-750-AST 75 GPM units together to pretreat a single 150 GPM flow from a kitchen.

The FSH Horizontal Flow Splitter is constructed of durable stainless steel and comes in two sizes. The FSH-44 has a 4" Inlet Coupling and splits off into two 4" Outlet Couplings. The FSH-64 has a 6" Inlet Coupling and splits off into two 4" Outlet Couplings.

The FSH Horizontal Flow Splitter was designed with installation flexibility in mind. There are two Inlets on each FSH Module - one is plumbed to the kitchen effluent piping, while the other Inlet Coupling is capped with an End Cap (provided). This dual inlet design allows for installation of the Module for either leftward draining flows or rightward draining flows.

**Dual Big Dipper® W-500-IS systems with the FSH-44 Horizontal Flow Splitter.**  
**This arrangement will handle a 100 GPM flow distributed evenly between two 50 GPM Big Dipper Systems.**

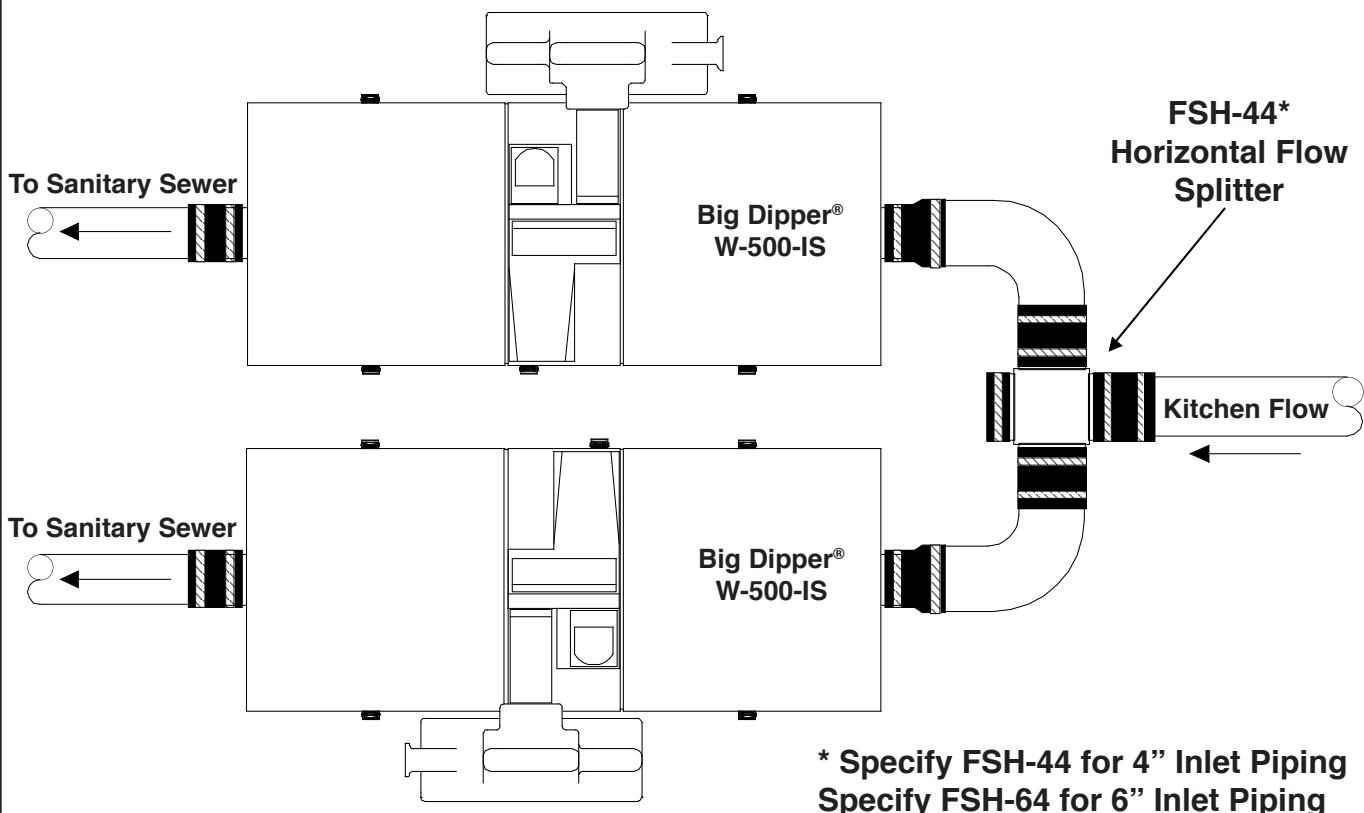



CZONE-1  
CleanZone™

The **Big Dipper® CleanZone™ Sanitary Shroud** (Part # CZONE-1) prevents food particles & other kitchen debris from falling down between the back of Big Dipper unit and the wall of the installation. This option also allows for easier mopping around the Big Dipper unit. The CleanZone™ fits Big Dipper W-200-IS, W-250-IS and W-250-AST Point Source Grease Removal Units. It may be trimmed in the field to fit around baseboard moldings or drainage piping. Durable ABS material construction allows for easy field modification for narrow gaps between the wall and Big Dipper unit.

### Features:

- Fits Big Dipper W-200-IS, W-250-IS & W-250-AST Point Source Big Dipper Units
- Durable ABS Construction
- 10" in height, 8" maximum width
- Prevents food particles & other debris from dropping behind unit
- Allows easy mopping around Big Dipper unit
- Field modifiable

CZONE-1 CleanZone™  
Trimmed to fit between  
Wall & Big Dipper unit

Moulding

Floor

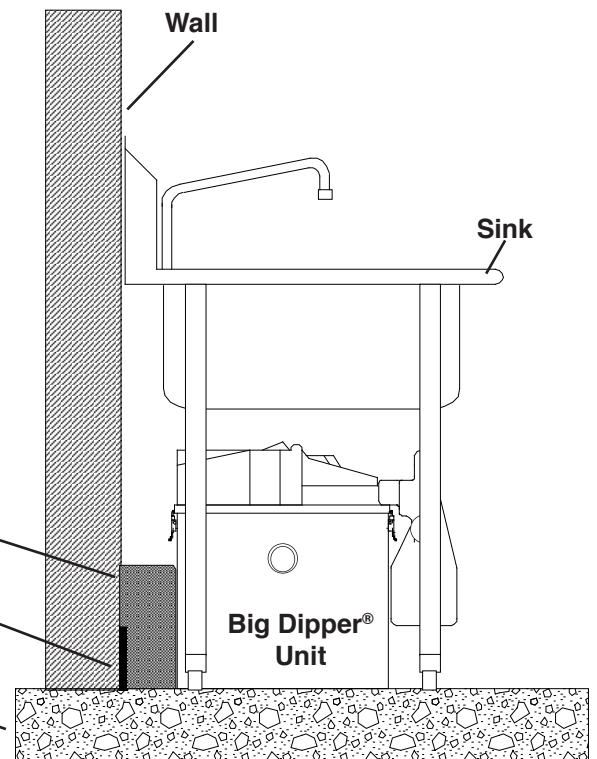

\*CZONE-1 CleanZone™ Patents/Patents Pending

©2007 Thermaco, Inc. All rights reserved • Patented/Patents Pending • Specifications subject to change without notice

Sometimes space restrictions require the installation of Big Dipper units in basement locations where significant head pressure becomes a factor. The **Big Dipper® VFCA Vented Flow Control** module provides an option for use with installations where a significant amount of head pressure is present (greater than 6 ft./1.95 m) or where applicable regulations require vented flow controls. A Vented Flow Control helps reduce problems associated with high head pressure and helps slow the drainwater flow down. The VFCA kit contains an appropriate fitting and flow control orifice.

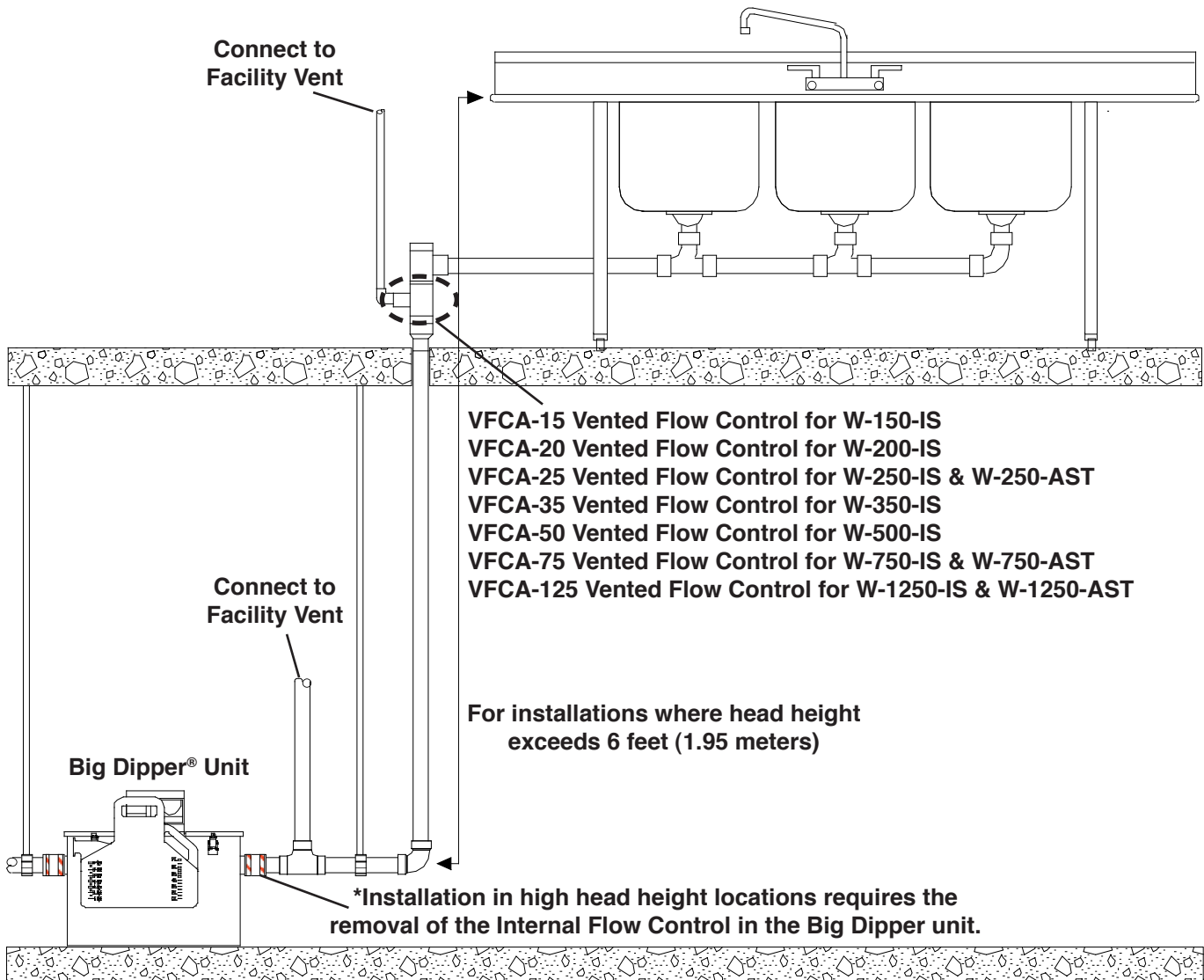

**NOTE: Drawing for reference only. Equipment must be installed in compliance with all applicable laws, regulations and codes, including plumbing codes. Installation should be performed by a qualified plumber.**